



Electrolux
PROFESSIONAL

Modular Cooking Range Line
thermaline 90 - 600 mm Passthrough
base, 2 doors, GN conform, 2 Sides (H2)
- H=450

ITEM # _____

MODEL # _____

NAME # _____

SIS # _____

AIA # _____



589197 (MC2DCCFOOO)

Passthrough Base, with 2 doors, two-side operated, GN - H2

Short Form Specification

Item No. _____

600 mm wide passthrough base compartment with 2 doors, to store pots, pans, sheet pans, etc. with hygienic design and round edges. Unit constructed according to DIN 18860_2 with 70 mm recessed plinth. Internal frame for heavy duty sturdiness in stainless steel. Flat surface construction, easily cleanable. Open storage space in the base accepts GN 1/1 containers.

IPX5 water resistant certification.

Configuration: Two-side operated freestanding base, hygienic class H2.

Main Features

- IPX5 water resistance certification.
- All major components may be easily accessed from the front.
- THERMODUL connection system creates a seamless work top when units are connected to each other thus avoiding soil penetrating vital components and facilitating the removal of units in case of replacement or service.
- Unit constructed according to DIN 18860_2 with 70 mm recessed plinth.

Construction

- Hygienic design of the open base compartment with large round edges.
- 2 mm top in 1.4301 (AISI 304).
- Flat surface construction with minimal hidden areas to easily clean all surfaces
- Storage space in the base of the appliance that can accept GN1/1 containers.
- Internal frame for heavy duty sturdiness in stainless steel.

APPROVAL: _____



Experience the Excellence
www.electroluxprofessional.com

Front

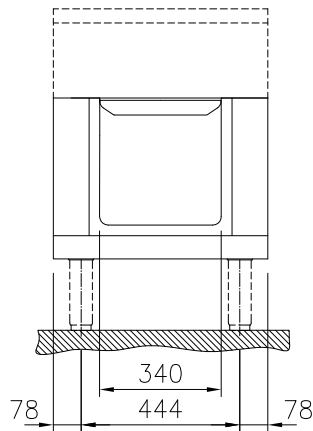

Key Information:

External dimensions, Width:	
589197 (MC2DCCFOOO)	600 mm
External dimensions, Depth:	900 mm
External dimensions, Height:	450 mm
Cupboard Cavity Dimensions (width):	340 mm
Cupboard Cavity Dimensions (height):	330 mm
Cupboard Cavity Dimensions (depth):	810 mm
Net weight:	28 kg

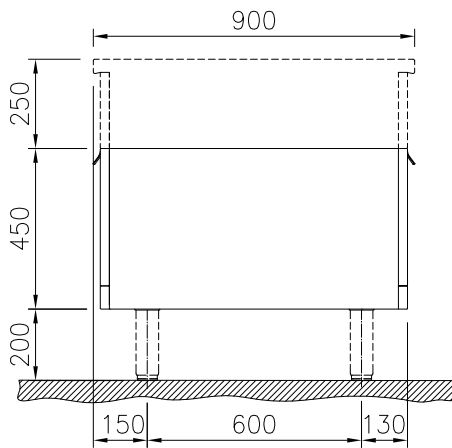
Side

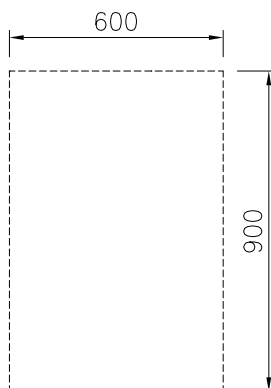

Top



Optional Accessories

- Stainless steel side panel, 900x700mm, freestanding PNC 912512
- Stainless steel front kicking strip, 600mm width PNC 912632
- Stainless steel side kicking strip left and right, freestanding, 900mm width PNC 912657
- Stainless steel plinth, freestanding, 600mm width PNC 912956
- Perforated shelf for warming cabinets and cupboard bases (two-side operated for TL90) PNC 913236
- Side reinforced panel only in combination with side shelf, for freestanding units PNC 913260
- Shelf fixation for TL90 two-side operated PNC 913280
- Stainless steel dividing panel, 900x700mm, (it should only be used between Electrolux Professional thermaline Modular 90 and thermaline C90) PNC 913672
- Stainless steel side panel, 900x700mm, flush-fitting (it should only be used against the wall, against a niche and in between Electrolux Professional thermaline and ProThermetic appliances and external appliances - provided that these have at least the same dimensions) PNC 913688